

3 Environmental working conditions

- Ambient air temperature: Up limit + 40°C, down limit - 15°C.
Storage and transportation at - 25°C is permissible.
- Altitude above sea level: Not over 1000 meters.
- Air relative humidity: Daily average value not over 95% and monthly average value not over 90% .
- Water steam pressure: Daily average value not over 2.2 kPa and monthly average value not over 1.8 kPa.
- Earthquake intensity: Not over 8 level. No dust, fume, corrosive or combustible gas, vapor or salt mist contaminate ambient air apparently.
- The amplitude value of electro-magnetic disturbance induced in secondary system not over 1.6 kV.

If our customers install this circuit breaker in conditions other than the above described, please contact our company to determine permissible scope and technical measures through discussion.

4 Technical parameters

No.	Description	Unit	Value		
1	Rated voltage	kV	12		
2	Rated frequency	Hz	50		
3	Rated power frequency withstanding voltage (to earth / between breaks) (1min)	kV	42 / 48		
4	Rated lightning impulse withstanding voltage (to earth / between breaks) (peak value)	kV	75 / 85		
5	Rated current	A	630 1250	630, 1250, 1600, 2000, 2500, 3150	1250, 1600, 2000, 2500, 3150, 4000*
6	Rated short circuit breaking current	kA	25	31.5	40
7	Rated short time withstanding current (4s)	kA	25	31.5	40
8	Rated short circuit making current	kA	63	80	100
9	Rated peak value withstanding current	kA	63	80	100
10	Rated short circuit current breaking operations		≥ 20		
11	Rated operating sequence		O-0.3s-CO-180s-CO	O-180s-CO-180s-CO	
12	Mechanical endurance		10000		
13	Power frequency withstanding voltage exerted on auxiliary circuits (1min)	V	2000		
14	Contact distance	mm	9 ± 1		
15	Spring travel under contact pressure (over travel)	mm	4 ± 1		
16	Discrepancy time among contacts in closing and opening operations	ms	≤ 2		
17	Contact pumping time in closing operation	ms	≤ 2		
18	Closing time	ms	35 ~ 70		
19	Opening time	ms	20 ~ 50		
20	Closing speed	m/s	0.4~0.8 (full distance before closing operation)		
21	Opening speed	m/s	0.9~1.3 (full distance after opening operation)		
22	Resistance of primary circuit	μΩ	630A: ≤55; 1250A: ≤45; 1600A, 2000A: ≤35; 2500A, 3150A, 4000A: ≤25		

* Note: Inside the 4000A cubicle, forced air cooling is desired.

5 Structure

5.1 General

The general structure of breaker is in form of operating mechanism box laid out in front and the solid insulation embedded pole laid out at rear. The primary circuit is arranged in three-phase fall-to-ground structure. The mechanism box contains all mechanical and electrical units which can be used to make closing or opening operation of the circuit breaker. By solid insulation embedded pole, it is actually an arc chamber made from epoxy resin through APG technological process covering and sealing all primary conducting circuits as a whole resulting in great independence from all kinds of environments outside.

5.2 Operating mechanism

The plane layout spring operating mechanism has two functions: manual energy storing and motor-driven energy storing. The operating mechanism is placed in a cabinet in front of arc interrupter. The cabinet is divided into five assembly compartments by four partitions in between. In the five compartments, there are energy storing part, driving part, tripping part and buffering part. This integral layout scheme is rational in structure so that the operating performance of mechanism is in better agreement with desired performance for opening and closing operations by the arc interrupter. It avoids unnecessary intermediate transmission, reduces energy consumption and annoying noise so that the operating performance of the breaker is more reliable.

● Energy storing operation

The energy needed for closing operation is provided by closing springs and the energy storing is completed by a motor powered from an external power supply or by manual operation through an energy storing handle.

For motor-driven energy storing operation, the motor output shaft 15 drives stopping pin 2 through sprockets 14, 23 and a chain 18. For manual operation, worm gear 13 and worm 11 drive sprockets to rotate energy storing shaft 7 and toggles 5, 21 on the shaft by which the closing spring 10 is pulled to stretch for energy storing purpose. When energy storing is finished, the energy is kept by energy keeping pawl 9. Simultaneously, the link plate 24 on energy storing shaft makes energy storing indication board 25 turn to "Energy Stored" indication and turns off the auxiliary power supply to energy storing motor.

● Closing operation

If a closing signal is received (or closing pushbutton is pressed down) after energy is stored in mechanism, the moving iron core of closing solenoid 12 picks up and moves forward to make energy keeping shaft 19 drive the keeping pawl rotating to release constraint of energy storing shaft 7. Then the energy in closing spring 10 releases, making closing cam 22 rotate clockwise and driving link rod mechanism and insulation pulling rod 33 to move movable conducting rod upward into closing position, and compressing contact spring 32 to keep desired contacting pressure for the contact.

After closing operation is completed, the closed position is retained by the closing keeping pawl 38 and half shaft 41. Simultaneously, the power supply circuit for energy storing indication board and energy storing auxiliary switch reset motor are energized to enter energy storing status again. At this, link rod 44 pulls ON/OFF indication board to show Closed indication and makes changeover of the main auxiliary switch.

Note: When the circuit breaker is already in closed status or blocking status not released, or truck type circuit breaker is in the course of pushing into and pulling out from the switchboard, the closing operation cannot be done.

- Opening operation

If an opening signal is once received (or opening pushbutton is pressed down) after closing operation is completed, the opening solenoid will act. Under the tripping force, the half shaft 41 will rotate in a clockwise direction resulting in releasing constraint of opening trip by the half shaft. Under the effects of contact pressure spring 32 and opening spring 35, the opening trip will rotate in clockwise direction. Driven by link rod mechanism and insulation pulling rod 33, the moving contacts of vacuum interrupter 28 will move downward to finish opening operation. At late section of opening time, the residual energy from opening course will be absorbed by a hydraulic buffer and the circuit breaker is limited in opening position.

Open indication is shown in On/Off indication board pulled by the link rod 44. At same time, a counter is driven to realize counting and the counter is controlled by the changeover of a main /auxiliary switch through a link rod.

5.3 Interlocking for prevention from erroneous operation

This circuit breaker offers full reliable preventing functions against erroneous operation:

- After completion of closing operation, the circuit breaker cannot be closed again before opening operation is made;
- After completion of closing operation, the internal anti-pumping control circuit will de-energize the closing circuit to prevent of the breaker from reclosing operation before removal of the closing electrical signal in time;
- If a truck type circuit breaker is not moved exactly to the test position or working position, the circuit breaker cannot be made closing operation so as to prevent of a circuit breaker in closed status from entering load region;
- If a truck type circuit breaker in working position or test position is closed, the truck cannot be moved further so as to prevent of a circuit breaker in closed status from pulling out or pushing into load region;
- The circuit breaker may be equipped with a closed position blocking device as per customers' requirement. With this device, the manual closing operation is prohibited before secondary power supply is energized.



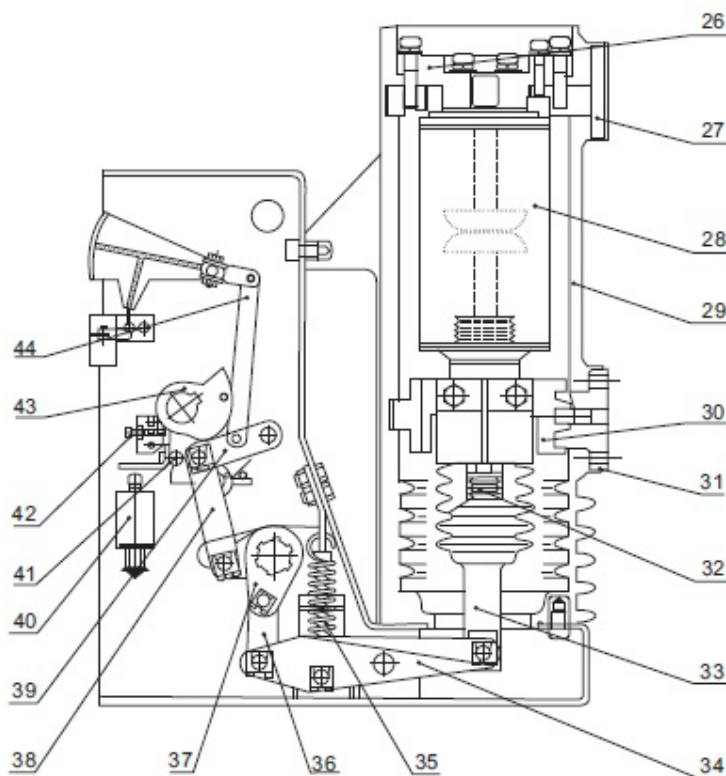
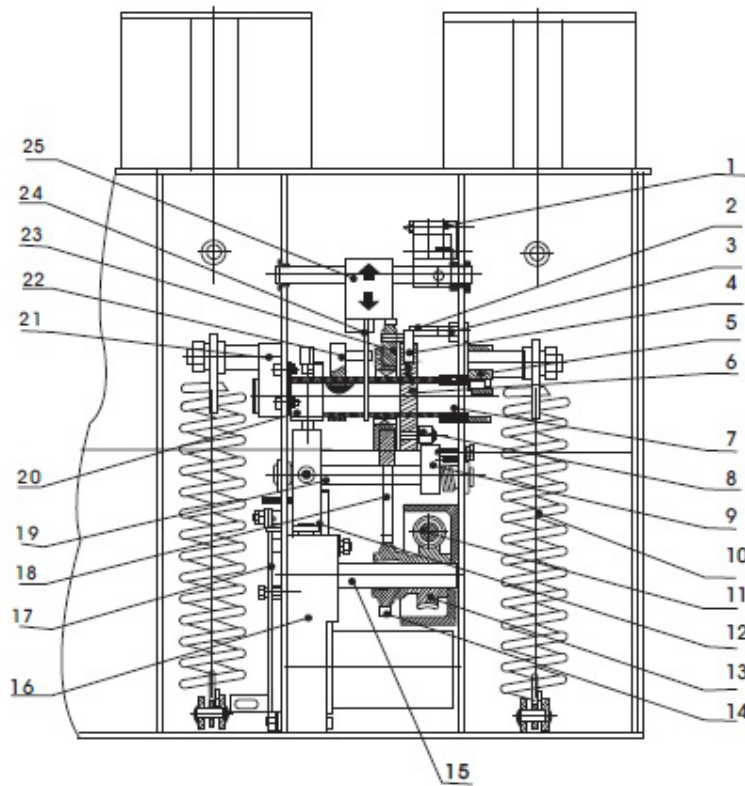

- 1 Micro-switch for energy storing changeover
- 2 Pin
- 3 Limit rod
- 4 Sliding block
- 5 Toggle
- 6 Driving wheel for energy storing
- 7 Energy storing shaft
- 8 Rolling wheel
- 9 Energy keeping pawl
- 10 Closing spring
- 11 Worm gear for manual energy storing
- 12 Closing solenoid
- 13 Worm for manual energy storing
- 14 Motor-driven sprocket
- 15 Motor output shaft
- 16 Energy storing motor
- 17 Interlocking driving bend plate
- 18 Driving chain
- 19 Energy keeping shaft
- 20 Blocking solenoid
- 21 Toggle
- 22 Cam
- 23 Driving sprocket for energy storing
- 24 Link plate
- 25 Energy storing indicating board
- 26 Up bracket
- 27 Up outgoing line holder
- 28 Vacuum interrupter
- 29 Insulating cylinder
- 30 Down bracket
- 31 Down outgoing line holder
- 32 Contact pressure spring
- 33 Insulated pulling rod
- 34 Driving crank arm
- 35 Opening spring
- 36 Driving link plate
- 37 Driving crank arm for main shaft
- 38 Keeping pawl for closing operation
- 39 Link plate
- 40 Opening coil
- 41 Half shaft
- 42 Pushing rod manual opening operation
- 43 Cam
- 44 On / Off indicating board

6 Overall dimensions of the circuit breaker

6.1 Overall dimensions of truck type vacuum circuit breaker

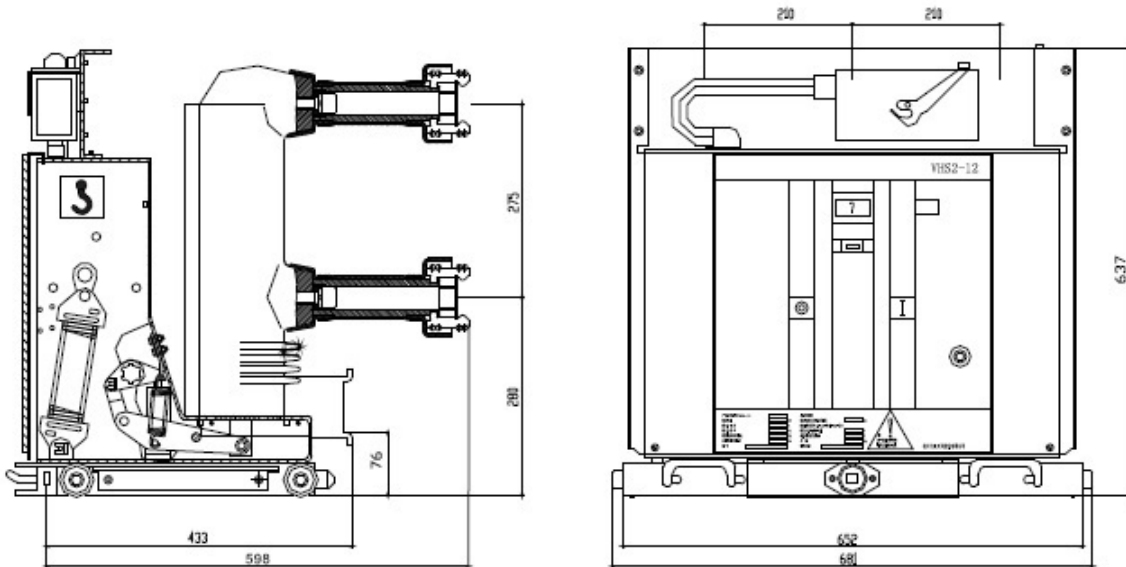

Rated current (A)	630	1250	1600
Rated short circuit breaking current (kA)	25, 31.5	25, 31.5, 40	31.5, 40
Matching dimension of fixed contact (mm)	φ 35	φ 49	φ 55

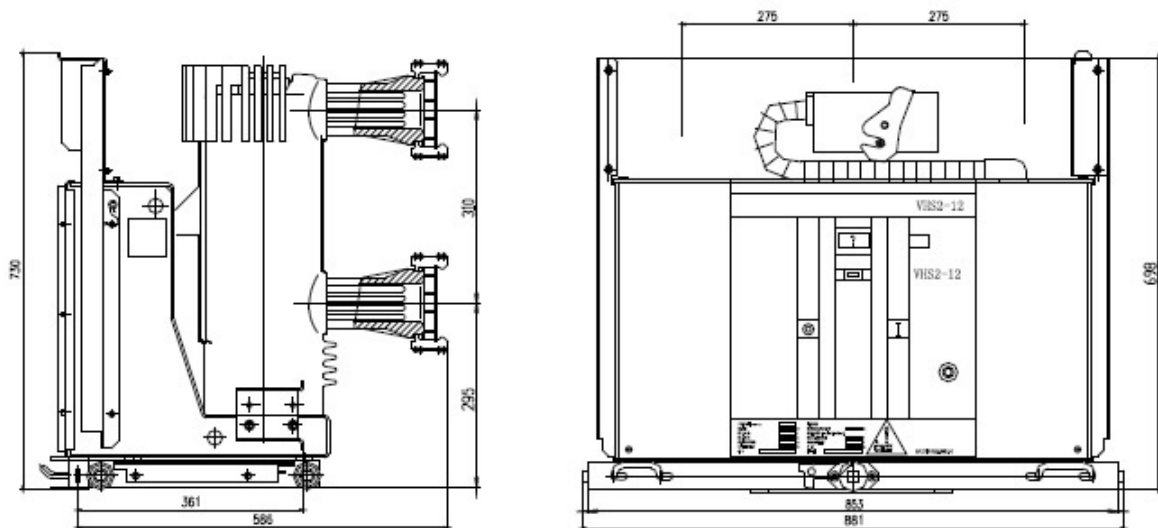

Rated current (A)	1600	2000	2500	3150	4000*
Rated short circuit breaking current (kA)	31.5, 40	31.5, 40	31.5, 40	31.5, 40	40
Matching dimension of fixed contact (mm)	φ 79			φ 109	

* Note: Inside 4000A cubicle, forced air cool is desired.

6.2 Overall dimensions of fixed type vacuum circuit breaker

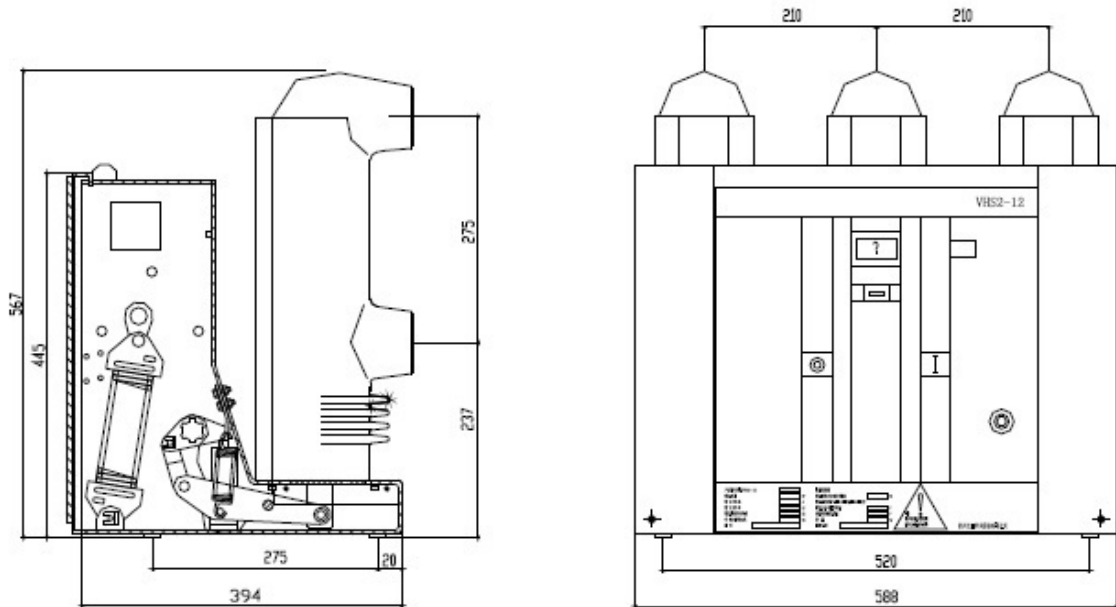

Rated current (A)	630	1250	1600
Rated short circuit breaking current (kA)	25, 31.5	25, 31.5, 40	31.5, 40

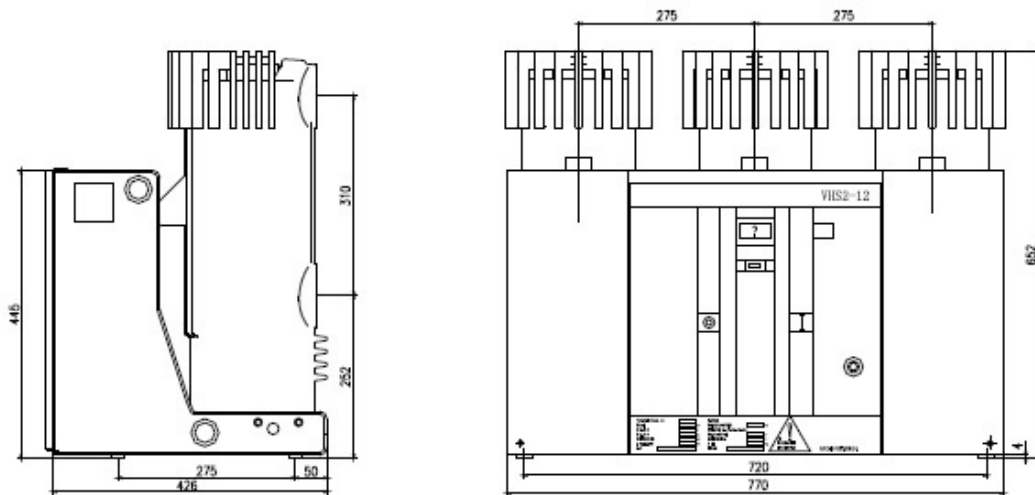

Rated current (A)	1600	2000	2500	3150	4000*
Rated short circuit breaking current (kA)	31.5, 40	31.5, 40	31.5, 40	31.5, 40	40

* Note: Inside 4000A cubicle, forced air cool is desired.

6.3 Recommended matching dimensions of the circuit breaker and cubicle in which the circuit breaker is installed

- Coordinative dimensions of a 800 mm width cubicle with the circuit breaker installed as shown

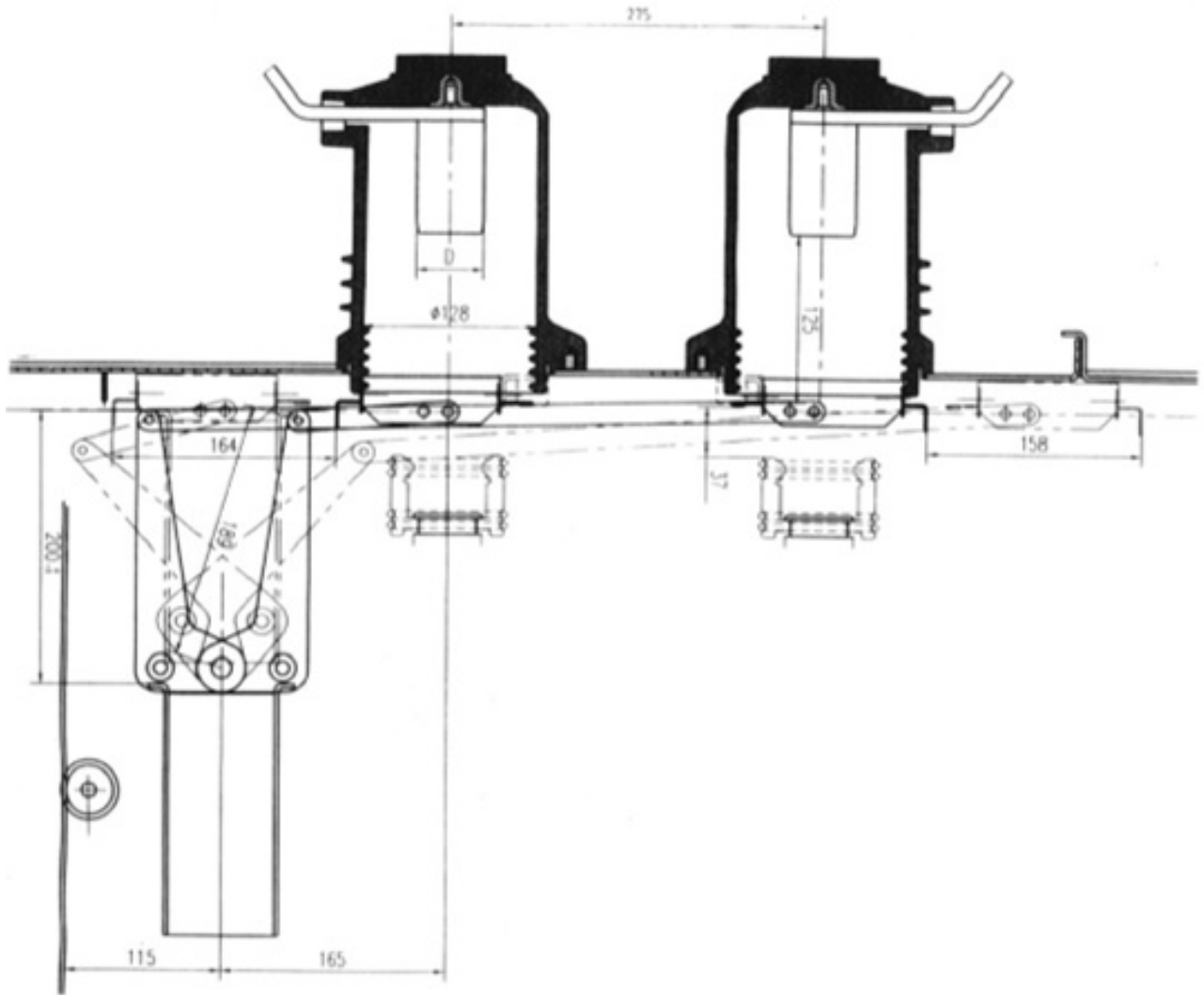

Rated current (A)	630	1250	1600
Rated short circuit breaking current (kA)	25, 31.5	25, 31.5, 40	31.5, 40
Coordinative dimensions for fixed contact (D)	φ 35mm	φ 49mm	φ 55mm

- Coordinative dimensions of a 1000 mm width cubicle with the circuit breaker installed as shown

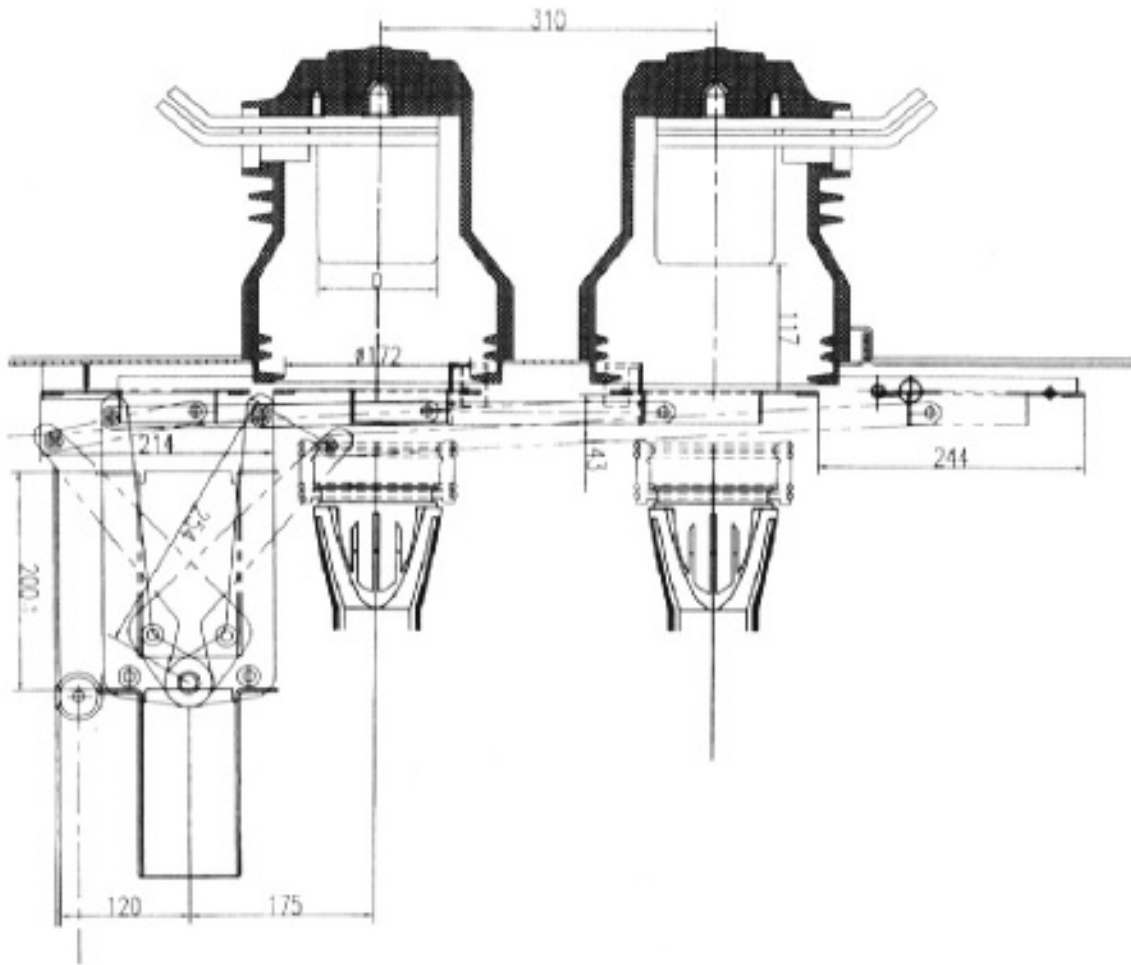

Rated current (A)	1600, 2000	2500	3150	4000*
Rated short circuit breaking current (kA)	31.5, 40			40
Coordinative dimensions for fixed contact (D)	Φ 79mm		Φ 109mm	

* Note: Inside 4000A cubicle, forced air cool is desired.

- Coordinative dimensions of moving and fixed contacts

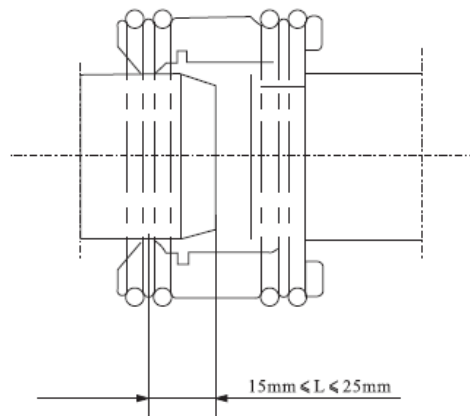

6.4 Installation dimensions of earthing device

- For VHS2 (800)

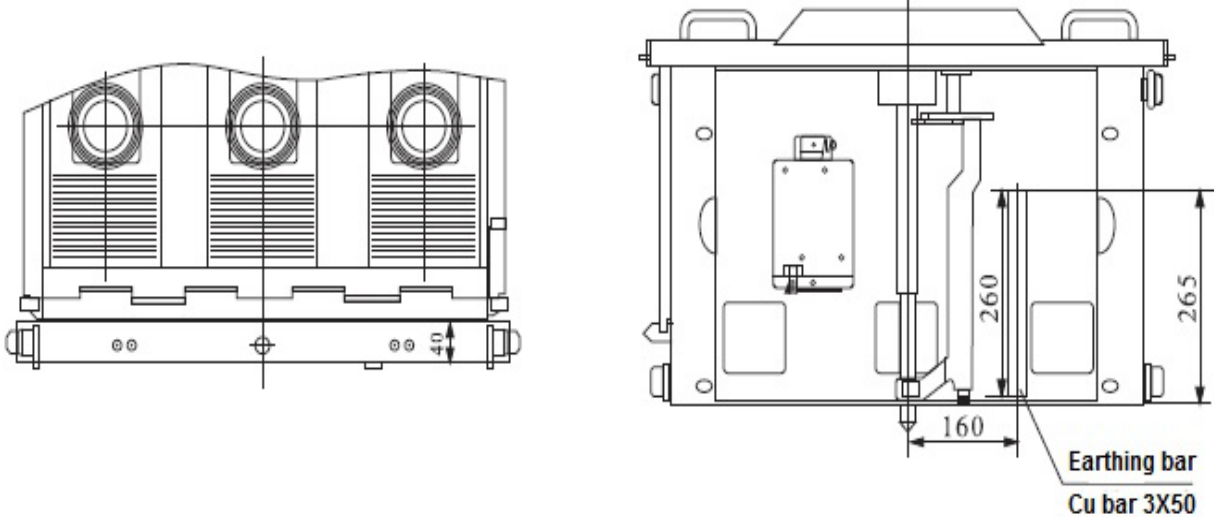

- For VHS2 (1000)

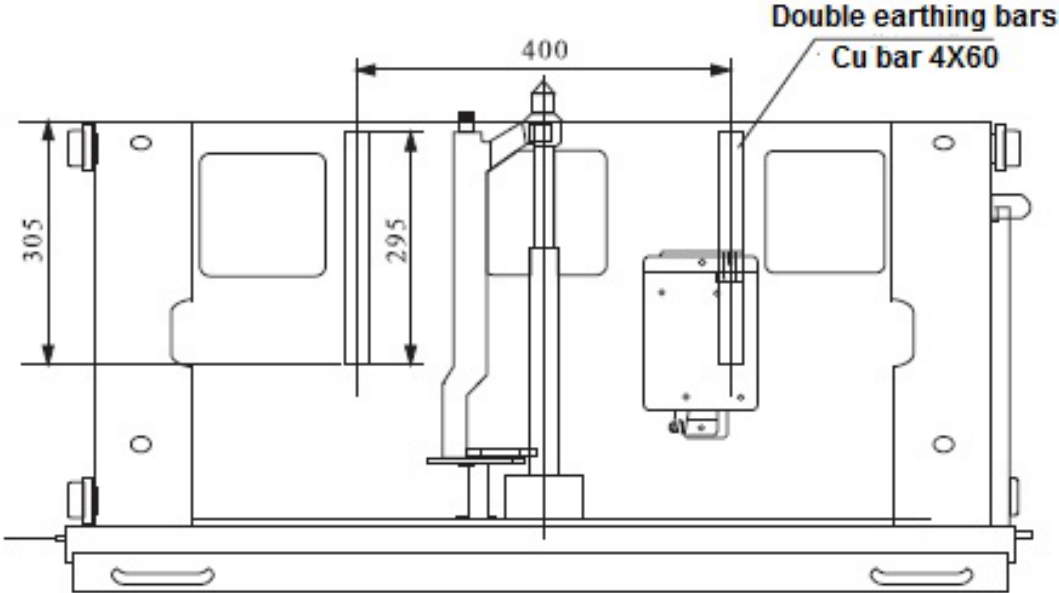

7 Wiring diagram of internal apparatus for the circuit breaker

7.1 Wiring diagram of internal apparatus for withdrawout type circuit breaker

The VHS 2 Circuit Breaker is in test position without energy stored, in opening status as shown in the picture

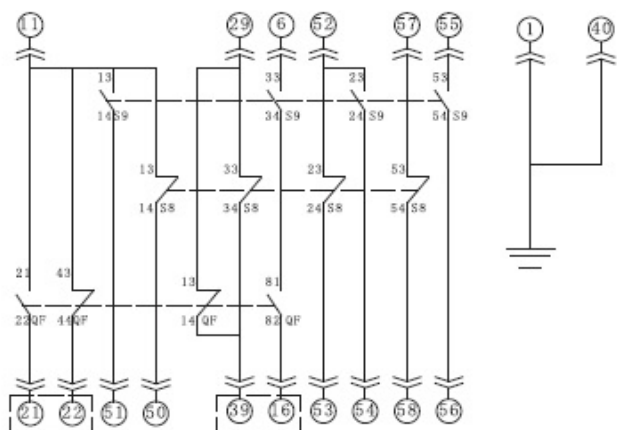
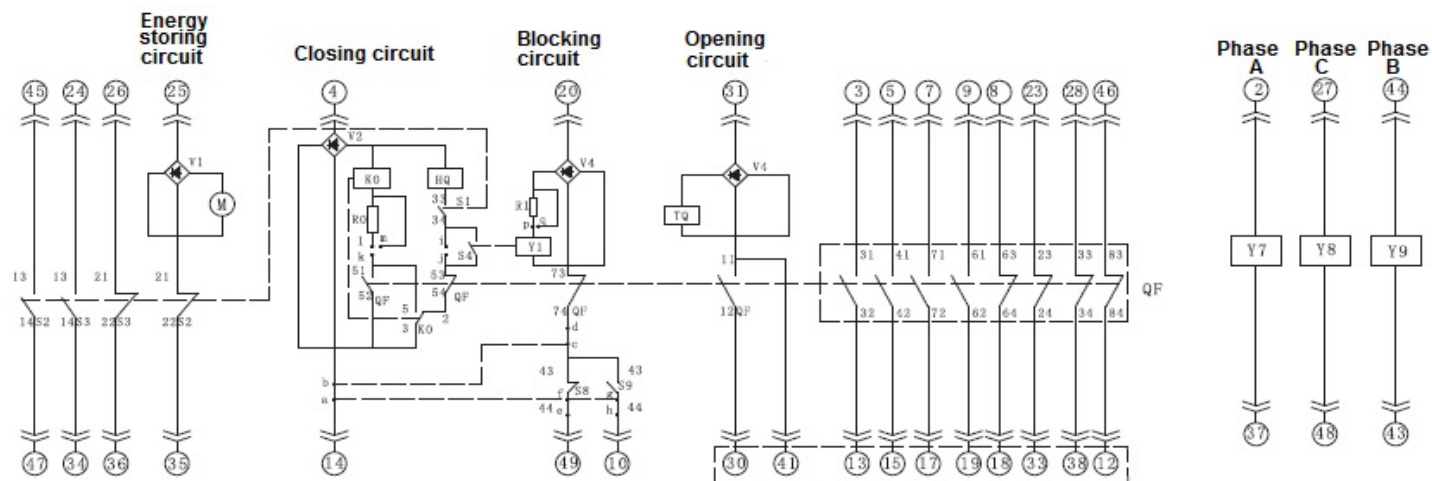

Note:

HQ: Closing coil
 TQ: Opening coil
 M: Energy storing motor
 S1, S2, S3: Micro-switch for energy storing
 QF: Auxiliary switch for C/O operation
 Y7, Y8, Y9: Indirect overcurrent trip coils (optional)
 Y1: Blocking solenoid (optional)
 KO: Anti-pumping relay (optional)
 S8: Auxiliary switch for test position
 S9: Auxiliary switch for working position
 S4: Auxiliary switch for blocking solenoid
 R0, R1: Resistors
 V1, V2, V3, V4: Bridge rectifier

Description:

- 1 In the drawing, VHS2 in test position without energy stored, in opening status;
- 2 If operating power supply is DC, the polarity in dotted line block should be same.

Function configured	Note for jumper wire
With anti-pumping	Short connect k & 1
No anti-pumping	Not short connect k & 1
With blocking	Short connect a&b, e&d, e&f, g&h
No blocking	Short connect a&f, a&g, b&c, i&l
AC/DC 220V	Not short connect a&1, p&q
AC/DC 110V	Short connect a&1, p&q

7.2 Wiring diagram of internal apparatus for fixed type circuit breaker

The VHS 2 Circuit Breaker is in opening status without energy stored as shown in the picture

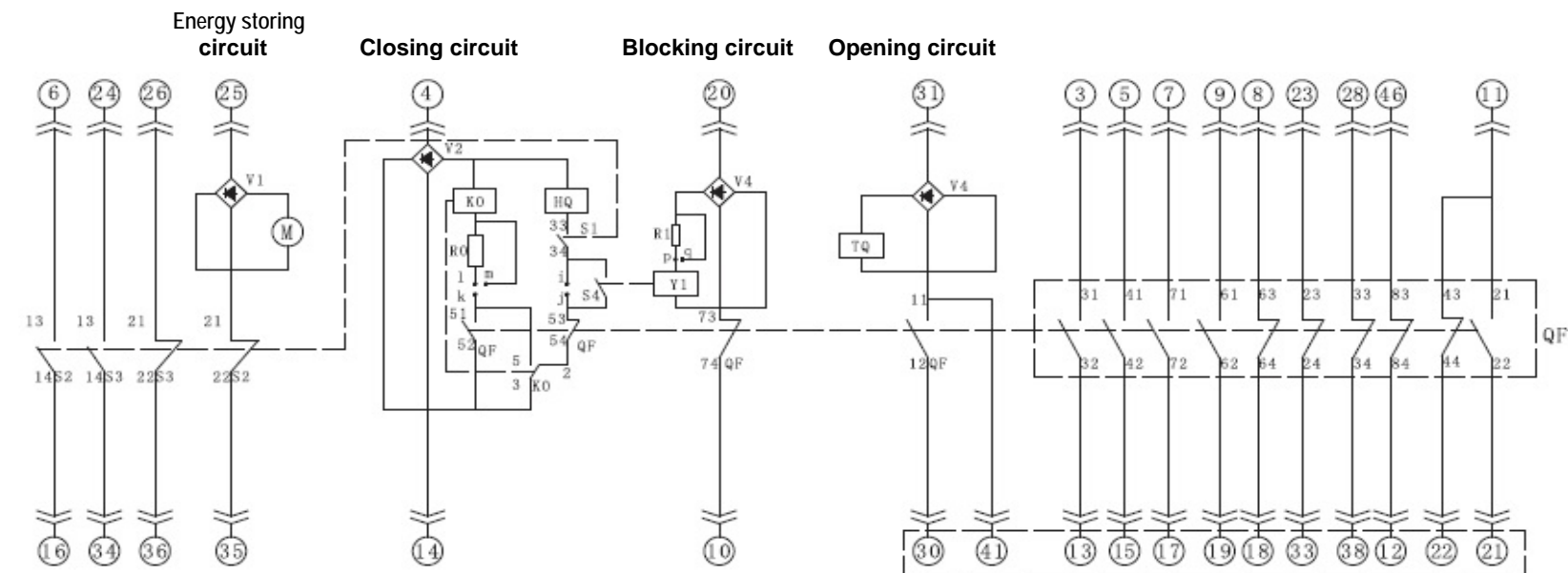

Phase A Phase C Phase B

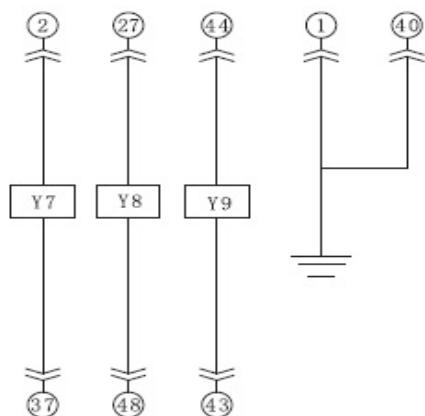

Note:

HQ: Closing coil
 TQ: Opening coil
 M: Energy storing motor
 S1, S2, S3: Micro-switch for energy storing
 QF: Auxiliary switch for C/O operation
 Y7, Y8, Y9: Indirect overcurrent trip coil (optional)
 Y1: Blocking solenoid (optional)
 KO: Anti-pumping relay (optional)
 S4: Auxiliary switch for blocking solenoid
 R0, R1: Resistors
 V1, V2, V3, V4: Bridge rectifier

Description:

- 1 In the drawing, VHS2 in test position without energy stored, in opening status;
- 2 If operating power supply is DC, the polarity in dotted line block should be same.

Function configured	Note for jumper wire
With anti-pumping	Short connect k & 1
No anti-pumping	Not short connect k & 1
With blocking	Not short connect l & j
No blocking	Short connect l & j
AC/DC 220V	Not short connect m & 1, p & q
AC/DC 110V	Short connect m & 1, p & q

8 Application and maintenance

8.1 Inspection before installation

- After unpacking, inspection should be made to see whether there is a damage in the circuit breaker, whether the product name plate and the certificate comply with ordering sheet. Only everything is OK can we do away with dust and pollution on surface especially on insulated surface;
- Manual operations of energy storing, closing and opening should be made on the circuit breaker as per regulations and pay attention to watch whether the relevant indications are correct or not;
- Motor-driven operations of energy storing, closing and opening should be made on the circuit breaker as per regulations and pay attention to watch whether the relevant indications are correct or not;
- Perform power frequency withstanding voltage test;
- Insert a specially propelling handle into the propelling hole. If you rotate the handle in clockwise direction, the breaker will be pushed in. And if you rotate the handle in counterclockwise direction, the breaker will be withdrawn. The total propelling travel is 200mm. In opening status, rotate the handle uniformly to working position or test position with a moderate speed by 20 turns until a click is heard, meaning the breaker is in right place. At same time, the relevant indicating signal lamp on cubicle is on. Avoid abrupt force exerted in order not to hurt interlocking mechanism and position signal.

8.2 Maintenance and service

- For normally operated circuit breaker, regular maintenance is necessary, including dust cleaning away from insulating surface, lubricating oil pouring in driving and friction parts periodically among others.
- The insulation test should be made at least once a year so as to judge whether there is leakage in vacuum interrupter, or whether there is deterioration of insulating intension caused by external factors.
- If the circuit breaker is stored for a long time, the internal moving parts of a circuit breaker would be retardant, therefore, operation of energy storing, opening and closing should be regularly conducted at least 5 times a year.
- To prevent from unexpected accidents, lubrication of operating mechanism and miscellaneous work should be done under the breaker in opening status without energy stored.
- For a circuit breaker to be operated frequently, operating cycles and short circuit current breaking operations should be strictly controlled in specified number by technical specification. Continuous application after rated endurance time is prohibited.
- Electrical components whose type and specification other than specified in original ones should not be replaced or applied by customers arbitrarily.

8.3 Abnormal situations possibly happened in operation

Serial number	Situation	Cause
1	Closing operation cannot be done	1 No energy stored
		2 In closed status already
		3 Truck type breaker is not in working position or test position entirely
		4 Closing blocking device is selected with auxiliary power not energized or lower than requirements in technical conditions
		5 Incorrect secondary circuit
2	Pushing in and pulling out is not possible	1 Breaker in closed status
		2 Propelling handle not inserts into propelling hole in safe
		3 Propelling mechanism not in test position entirely so latching plate and cubicle not released
		4 Cubicle earthing interlocking not released

9 Handling and storage

9.1 Handling

When lift the breaker from packaging case, a hook should be placed firmly on hoist well. Not any force should be exerted on up and down outgoing line arms. At the same time, greater shock and vibration on the breaker is not permissible either.

9.2 Storage

- Before application, the breaker should be stored in a dried, ventilated, moisture proof, shock proof room without intrusion of harmful gas, and it should be inspected regularly to make sure whether the environment complies with requirements.
- When in storage, the circuit breaker must be in open position and the spring operating mechanism should not be energy stored.
- The permissible storage term of vacuum interrupter is limited to 20 years.

10 Documents attached to the product

10.1 Product Certificate

10.2 Delivery Inspection Report

10.3 Installation and Application Manual

10.4 Packing List

11 Ordering sheet

Ordering specification of VHS2 - 12 Indoor High Voltage Vacuum Circuit Breaker

It is necessary for our customers to have a mastery of knowledge of the product's technical information and order our product to be applied as per this Ordering Sheet later on.

Please mark a in

Customer						Ordering date							
Specification and type	Phase clearance	<input type="checkbox"/> 150mm (cubicle width 650)				<input type="checkbox"/> 210mm (cubicle width 800)				<input type="checkbox"/> 275mm (cubicle width 1000)			
	Type	Truck type / fixed type											
	Specification	Spec.	Qty	Spec.	Qty	Spec.	Qty	Spec.	Qty	Spec.	Qty	Spec.	Qty
		<input type="checkbox"/> 630 - 20		<input type="checkbox"/> 630 - 25		<input type="checkbox"/> 630 - 31.5		<input type="checkbox"/> 1250 - 25		<input type="checkbox"/> 1250 - 31.5		<input type="checkbox"/> 1600 - 25	
		<input type="checkbox"/> 1250 - 31.5		<input type="checkbox"/> 1250 - 40		<input type="checkbox"/> 1600 - 31.5		<input type="checkbox"/> 1600 - 40		<input type="checkbox"/> 2000 - 31.5		<input type="checkbox"/> 2500 - 40	
<input type="checkbox"/> 2000 - 31.5			<input type="checkbox"/> 2000 - 40		<input type="checkbox"/> 2500 - 31.5		<input type="checkbox"/> 2500 - 40		<input type="checkbox"/> 3150 - 31.5		<input type="checkbox"/> 4000 - 40		
Standard accessory	Opening trip	<input type="checkbox"/> AC / DC 220V						<input type="checkbox"/> AC / DC 110V					
	Closing trip	<input type="checkbox"/> AC / DC 220V						<input type="checkbox"/> AC / DC 110V					
	Energy storing motor	<input type="checkbox"/> AC / DC 220V						<input type="checkbox"/> AC / DC 110V					
Optional accessory	<input type="checkbox"/> Blocking device for closing operation	<input type="checkbox"/> AC / DC 220V						<input type="checkbox"/> AC / DC 110V					
	<input type="checkbox"/> Blocking device for pallet truck	<input type="checkbox"/> AC / DC 220V						<input type="checkbox"/> AC / DC 110V					
	<input type="checkbox"/> Anti-pumping Device *												
	<input type="checkbox"/> Undervoltage opening device	<input type="checkbox"/> AC / DC 220V						<input type="checkbox"/> AC / DC 110V					
	<input type="checkbox"/> Overcurrent trip	<input type="checkbox"/> 3.5 A	<input type="checkbox"/> Two-phase (Y7 Y8)				<input type="checkbox"/> Three-phase (Y7 Y8 Y9)						
		<input type="checkbox"/> 5 A	<input type="checkbox"/> Two-phase (Y7 Y8)				<input type="checkbox"/> Three-phase (Y7 Y8 Y9)						
	<input type="checkbox"/> Programmable lock for pallet truck	<input type="checkbox"/> Two steps into one / three steps into two / four steps into two						<input type="checkbox"/> Operation of door open / <input type="checkbox"/> operation of door closed (piercing a ϕ 36 hole is necessary)					
	<input type="checkbox"/> Interlocking middle doors	<input type="checkbox"/> Only when cubicle door closed can pallet truck be operated											
		<input type="checkbox"/> Only when cubicle door closed can pallet truck be operated + only when breaker in test position can cubicle door be open											
	<input type="checkbox"/> Earthing mode pallet truck *	<input type="checkbox"/> Normal earthing mode (bottom earthed by friction - earthing bar)											
		<input type="checkbox"/> Particular earthing mode (front terminal earthing contact - 4X 40 copper bar)											
		<input type="checkbox"/> Particular earthing mode (earthing clips on both sides)											
<input type="checkbox"/> Secondary wiring mode	<input type="checkbox"/> 8 NO 8 NC*				<input type="checkbox"/> 10 NO 10 NC				Particular requirement (wiring drawing attached)				
	<input type="checkbox"/> Fixed optional scheme	<input type="checkbox"/> Rotating shaft interlocking	<input type="checkbox"/> Opening interlocking on left side (normal)*				<input type="checkbox"/> Opening interlocking on left side + closing interlocking						
<input type="checkbox"/> Opening interlocking on right side				<input type="checkbox"/> Opening interlocking on right side + closing interlocking									
<input type="checkbox"/> Main shaft protrudes out (spline shaft)		<input type="checkbox"/> Main shaft protrudes out on left side by 50mm											
		<input type="checkbox"/> Main shaft protrudes out on right side by 50mm											
Remarks													

- Note: 1 The optional accessories are fee charged items except for those with * ;
 2 Closing interlocking and closing blocking cannot be shared.